



INGERSOLL[®]

since 1884

GET THE *EDGE*



Table of Contents

Origin of PURE Steel	4-5
Company History	6-7
Product Manufacturing	8-9
Product Selection Charts.....	10-12
SPECIALTY DISCS	13-24
SoilRazor® VT	14-15
SoilRazor® CT	16-17
SoilWave™	18-19
SoilRebel™	20-21
RadialRazor™	22-23
ResidueRazor®	24
CONCAVE TILLAGE DISCS	25-37
Plain Concave Discs	26-27
Notched Concave Discs	28-29
Plain Flat Center Discs	30-31
Rollable Boron Concave Discs.....	32-33
3-Sided Concave Discs	34-35
DuraFace™ Plain & Notched Discs	36-37
COULTERS	39-49
Plain Coulters - Flat & Notched.....	40-41
8 Wave Coulters.....	42-43
13 Wave Coulters	44-45
25 Wave Coulters	46-47
Rippled & Bubble Coulters	48-49
DISC WEIGHTS	50
PLANTING & SEEDING DISCS	51-55
Assembled Openers	52-53
Plain Openers & Covering Disc Assemblies	54-55
EDGE CARE™ PLUS DISC SHARPENER.....	56-57
SOIL RIPPER™ TILLAGE POINTS	58-59
HOLE CONFIGURATION OPTIONS	60-63
Worksheet Pages	64-65

IT'S THE **STEEL**

Ingersoll reaches deep into the earth to bring you steel products made from the finest **PURE** ingredients.

► *Virgin taconite mine*



Virgin Iron Ore Taconite



Ingersoll Steel is created with virgin iron ore taconite from North America. This amazingly unique steel is processed with Ingersoll's own proprietary formula to give it the perfect balance of strength and flexibility for long lasting top performance in the field.

There is no other steel like it.

Ingersoll's exclusive steel produces industry leading quality, reliability and performance. It supports the world's tillage equipment with the highest grade components.

Choose Ingersoll for all your high speed, high yield farming solutions.



PURE[™]
Performance Grade Steel



GET THE EDGE
INGERSOLL[®]



FROM EARLY INNOVATION...



In 1884, Steven Ingersoll took over a small coultter disc manufacturing company in Sandoval, Illinois. The discs produced there were the state of the art, back then, but everything was about to change.

Steven Ingersoll, together with his son Roy, successfully began experimenting with new heat treating processes and innovative manufacturing techniques.

Today, Ingersoll Tillage Group is known throughout the industry as the recognized leader for quality, durability and design of products that fulfill the needs of today's producers. The company's product line has become the top choice of major brand OEMs.

Hamilton, Ontario Manufacturing Plant, circa 1902

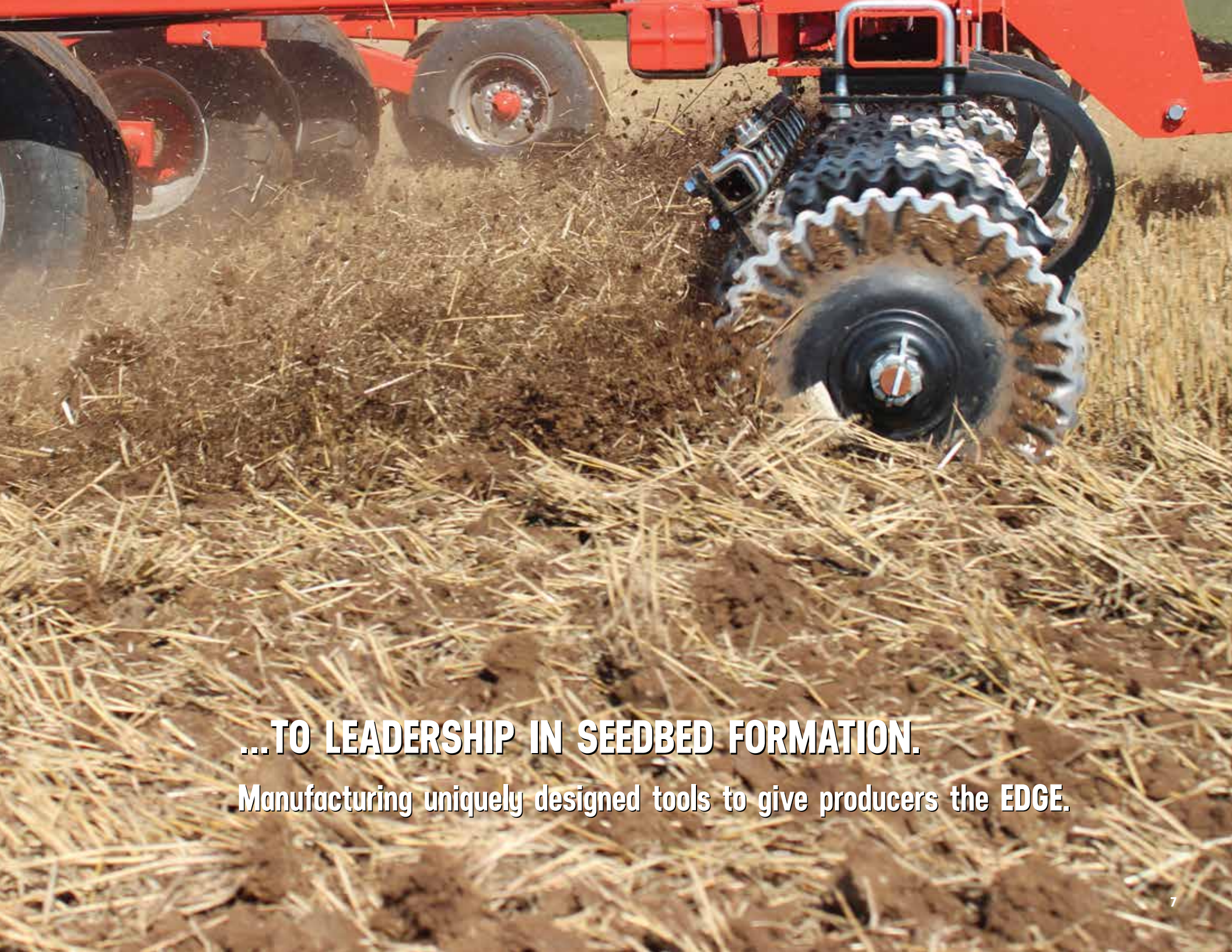
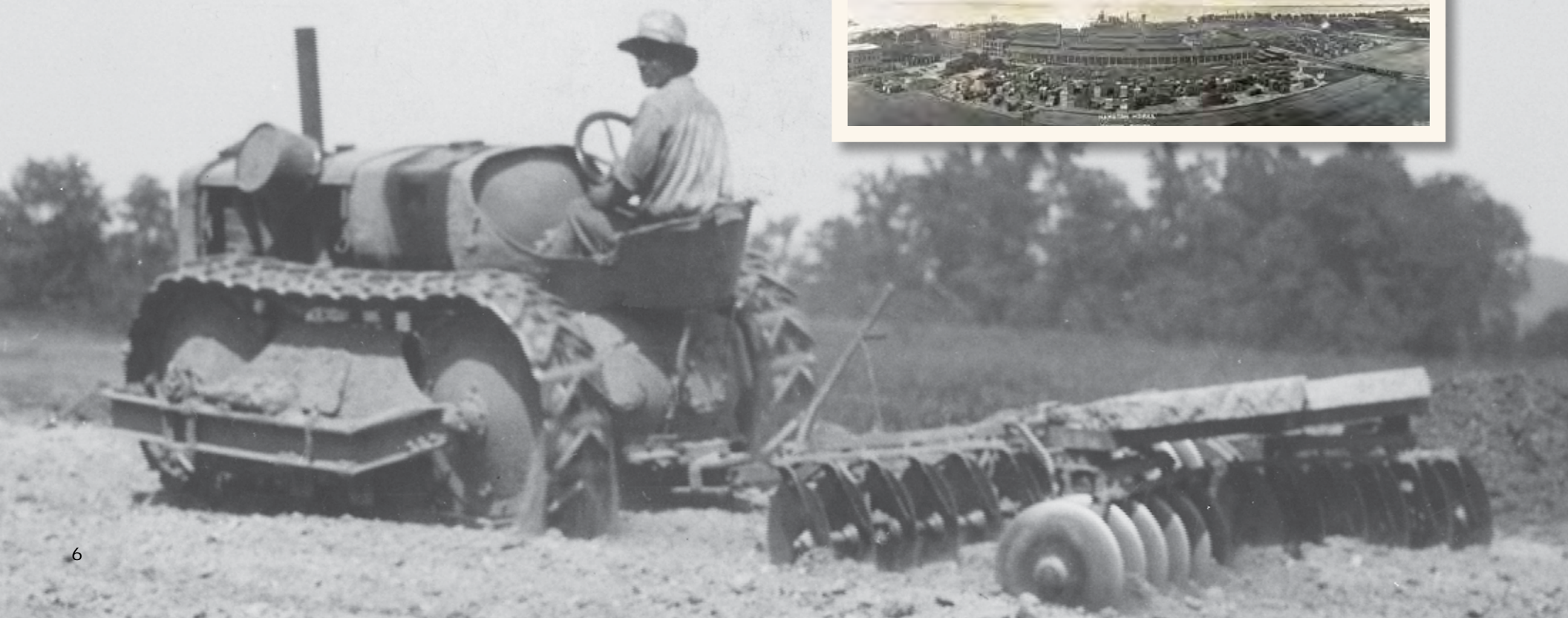

...TO LEADERSHIP IN SEEDBED FORMATION.

Manufacturing uniquely designed tools to give producers the EDGE.



Catalog Guide

The selection chart shown on the following pages is a good place to start. It helps you to choose the disc or coultter that's best suited for your needs.

Then, go to the catalog page indicated to select the specific product based on diameter, thickness, etc.

To help you determine the size and specs, we've provided handy worksheets in the back of this catalog for your use.

DISCS

Product Selection Chart

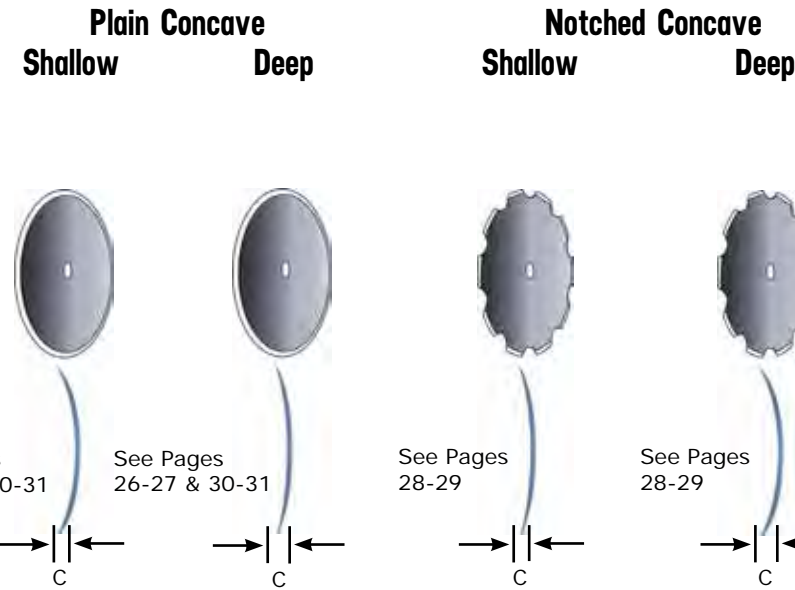

Factors	Qualities				
Aggressiveness	Low	X			
	Medium			X	
	High		X		X
Tillage Practice	Vertical	X		X	
	Conventional	X	X	X	X
Residue Management	Good		X		
	Better	X			X
	Best			X	
Seedbed Preparation	Good		X		
	Better	X			X
	Best			X	
Speed	Slow				
	Medium		X		X
	High	X		X	
Soil Penetration	Low				
	Medium	X		X	
	High		X		X

SPECIALTY COULTERS

Product Selection Chart

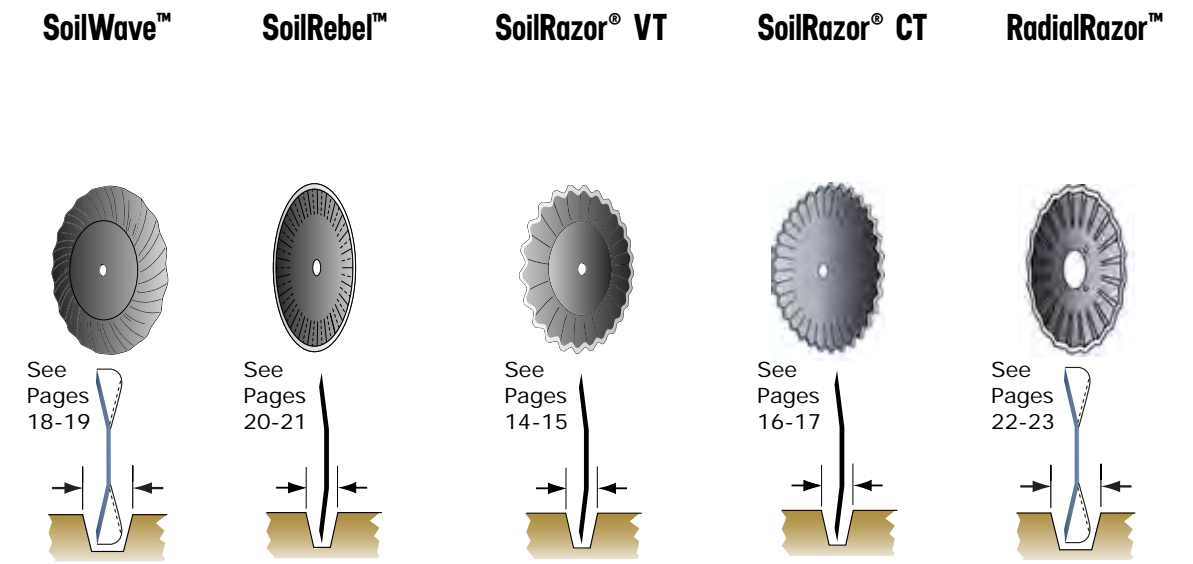

Factors	Qualities					
Aggressiveness	Low					X
	Medium	X	X			
	High			X	X	
Tillage Practice	Vertical	X	X	X		X
	Conventional	X			X	
Residue Management	Good					
	Better		X			
	Best	X		X	X	X
Seedbed Preparation	Good					
	Better	X	X	X	X	
	Best	X				X
Speed	Slow	X				
	Medium	X	X	X	X	X
	High	X	X	X		X
Soil Penetration	Low			X		
	Medium	X	X		X	
	High					X

COULTERS
Product Selection Chart

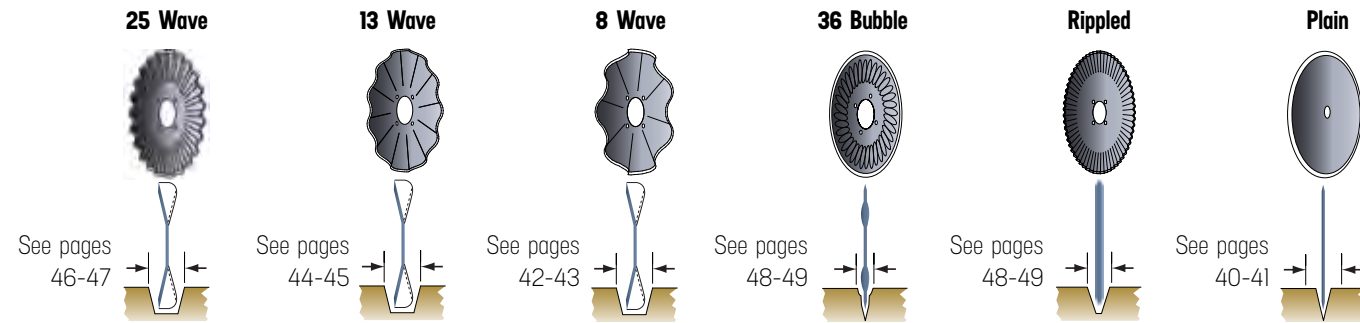

Factors	Qualities						
Aggressiveness	Low					X	X
	Medium	X			X		
	High		X	X			
Tillage Practice	No-Till	X	X	X		X	X
	Reduced Till	X	X	X	X	X	X
	Conventional	X	X	X	X		X
Fertilizer	Good						
	Better	X	X	X	X		
	Best					X	X
Residue Management	Good						X
	Better				X	X	
	Best	X	X	X			
Soil Conditions	Dry	X	X	X	X	X	X
	Damp/Sticky					X	X
	Sandy	X	X	X	X	X	X
	Heavy	X	X	X		X	X
Placement	Shallow	X	X	X	X		
	Deep					X	X
Soil Tilt	Coarse		X	X	X		
	Medium		X	X	X	X	
	Fine		X				
	Extra Fine	X					X
Speed	Slow	X	X			X	X
	Medium	X	X	X	X	X	X
	High	X	X	X	X	X	X

SPECIALTY DISCS

High performance ground-engaging tools uniquely designed for today's production needs. Available only from Ingersoll!



GET THE EDGE

Vertical Tillage

SOILRAZOR® VT
Extremely sharp edge

Ingersoll has developed the SoilRazor VT vertical tillage disc with a unique serrated edge that maintains its cutting ability as it wears, season after season.

Its wear factor is what makes the SoilRazor VT a breakthrough technology for the vertical tillage industry. The disc's serrated edge remains sharp through use providing a long-lasting cutting edge that maintains its ability to slice and size the toughest residue as it wears. Even at the highest speeds, the SoilRazor VT retains its durability and sharpness.

The SoilRazor VT has set new standards around the world for its innovative design and its exceptional ability to manage residue. These blades are made of Ingersoll's proprietary boron alloy steel for unmatched hardness with flexibility and wear resistance.



Continuous Sawtooth Wave Design

Full Concavity - 330mm no wave area

Diameter		Thickness mm	#	Waves		Concavity mm
inches	mm			Height inches	mm	
Deep						
18"	463.5	5	25	0.53	13.5	29.5
20"	520	5	25	0.53	13.5	40
22"	576	5	25	0.53	13.5	55
Shallow						
18"	465	5	25	0.53	13.5	26.5
20"	517	5/6.5	25	0.53	13.5	34
22"	569	5/6.5	25	0.53	13.5	43
24"	621	6.5	28	0.51	13.1	57.7

Flat Back (FCD:152mm)

Diameter		Thickness mm	#	Waves		Concavity mm
inches	mm			Height inches	mm	
Deep						
18	463	5	25	0.53	13.5	26.5
20	513	5/6.5	25	0.53	13.5	36.5
22	563	5	25	0.53	13.5	52
22	563	6.5	28	0.53	13.5	50.3
Shallow						
18	463.5	5	25	0.53	13.5	20.5
20	516	5/6.5	25	0.53	13.5	30.5
22	570	5/6.5	25	0.53	13.5	40
22	570	6.5	28	0.51	13.1	37
24	623	6.5	28	0.51	13.1	53.5

EDGE DETAIL
[Type 25]



SOILRAZOR® VT

Extremely sharp edge to cut the toughest residue

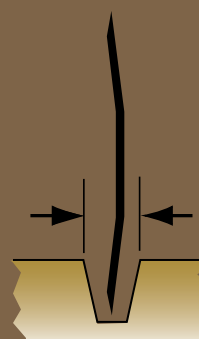
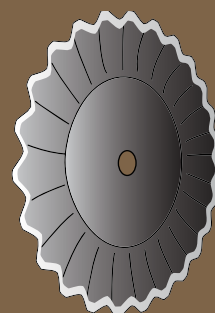

Aggressiveness

Tillage Practice **VERTICAL**

Residue management

Soil penetration

Speed

Seedbed preparation

Conventional Tillage

SOILRAZOR® CT
Extremely aggressive edge

The SoilRazor CT full concavity disc from Ingersoll is one of the most innovative products in the market. The unique saw-tooth design is extremely well-suited for cutting through the toughest of residue and penetrating deep into the soil.

The SoilRazor CT has excellent clod-crushing capabilities at normal working speeds and yields superior performance in soft soils. What's more, the cutting edge is maintained through use. So you can continue to work with it for season after season, even in the toughest of conditions.

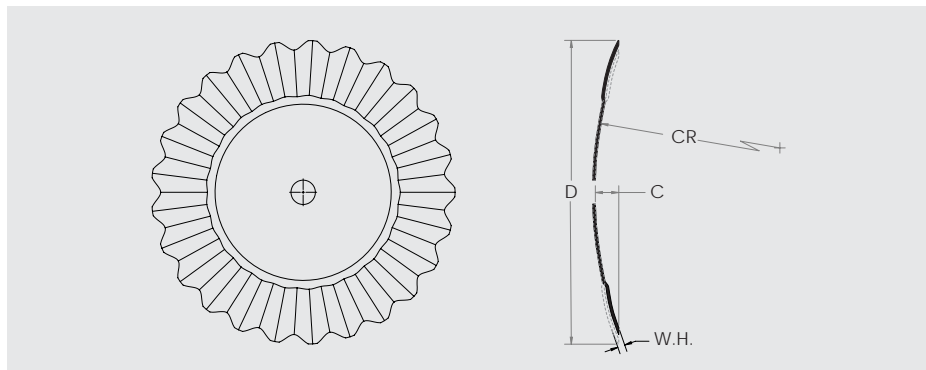

Continuous Sawtooth Full Concavity Design

Diameter		Thickness	#	Waves		Concavity
inches	mm	mm		Height		
				inches	mm	mm
20	508	4/5	32	0.43	11	44
22.25	560	4/5	32	0.43	11	55
24	610	5/6	32	0.47	12	65
26.25	666	5/6/8	32	0.49	12.5	82
28.50	724	6/8	32	0.53	13.5	100
30	762	8/9/12.5	32	0.61	15.5	100
32	813	8/9/12.5	32	0.61	15.5	115



EDGE DETAIL
[Type 25]



SOILRAZOR® CT

Extremely aggressive edge to cut the toughest residue with added soil coverage

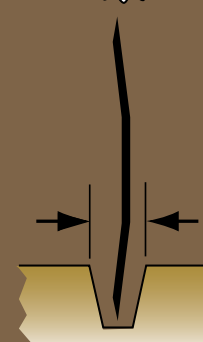
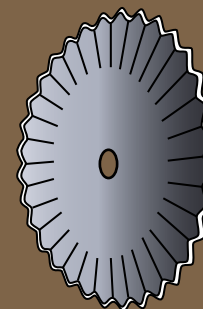

Aggressiveness
↑↑↑



Tillage Practice
CONVENTIONAL



Residue management
↑↑↑



Soil penetration
↑↑↑



Speed
↑↑↑



Seedbed preparation
↑↑↑



Vertical or Conventional Tillage

SOILWAVE™
Flat Coulter with Curved Wave Design

The Soilwave's curved waves work the soil without turning it over, while it cuts residue and incorporates it into the soil. This leaves an ideal mix of organic residue on the surface. Under the surface the soil is a well-prepared seedbed ready for planting.

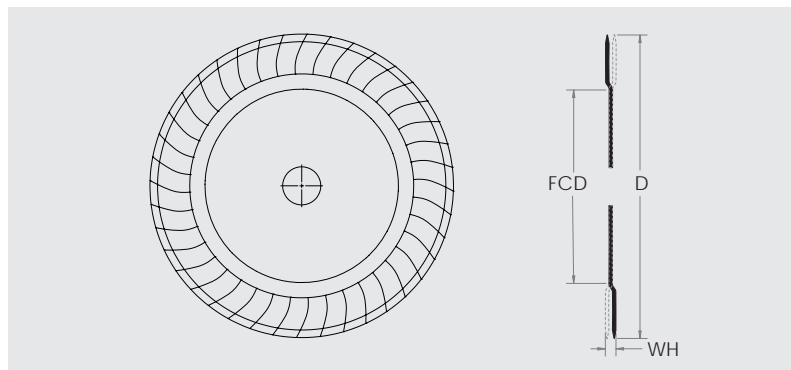

Flat Coulter with Curved Wave Design
20 waves. Height 5/8" - 15.9 mm.

Diameter		Thickness	FCD	
inches	mm	mm	inches	mm
16	398	4.5/5	10	254
17	428	5	10	254
18	458	5	10	254
20	517	5/6.5	12	305
22	562	6.5	12	305
22	573	5/6.5	12	305

EDGE DETAIL
[Type 21]

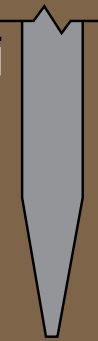

SOILWAVE™

Effective in both vertical and conventional tillage

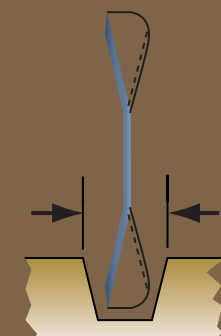
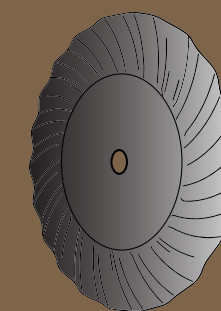

- Aggressiveness ↑↑↑
- Tillage practice **VERTICAL & CONVENTIONAL**
- Residue management ↑↑↑
- Soil penetration ↑↑↑
- Speed ↑↑↑
- Seedbed preparation ↑↑↑



Vertical Tillage

SOILREBEL™

Sizes and mixes residue with soil

The SoilRebel 25 wave concave coulters are designed for high speed operations while it produces less soil smearing and reduced compaction.

It is ideal for high speed vertical tillage.

This blade's aggressive wave profile is well designed for sizing and mixing residue with soil.

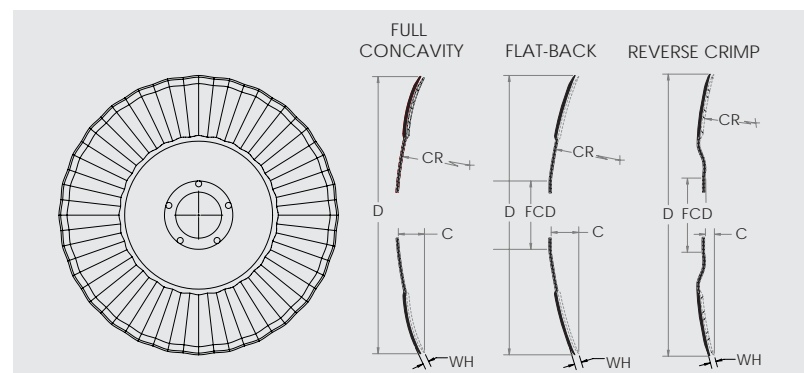

Full Concavity - 330 area with no wave

Diameter		Thickness mm	#	Waves		Concavity mm
inches	mm			#	Height inches	
Deep						
18	462	5	25	0.53	13.5	43.5
20	510	5/6.5	25	0.53	13.5	54
22	560	5/6.5	25	0.53	13.5	64
Shallow						
18	464	5	25	0.53	13.5	40.5
20	512	5/6.5	25	0.53	13.5	48
22	567	5/6.5	25	0.53	13.5	52

Flat Back (FCD:152mm)

Diameter		Thickness mm	#	Waves		Concavity mm
inches	mm			#	Height inches	
Deep						
18	462	5	25	0.53	13.5	33.5
20	513	5/6.5	25	0.53	13.5	45.8
22	560	5/6.5	25	0.53	13.5	49.3
Shallow						
18	464	5	25	0.53	13.5	27.5
20	517	5/6.5	25	0.53	13.5	37.5
22	567	6.5	25	0.51	13.1	49.5

Reverse Crimp (FCD:165mm)

Diameter		Thickness mm	#	Waves		Concavity mm
inches	mm			#	Height inches	
18	464	4	25	0.53	13.5	0
20	517	5/6	25	0.53	13.5	4.5
22	574	5/6/6.5	25	0.51	13.1	13

EDGE DETAIL
[Type 1]*



SOILREBEL™

Ideal for high speed vertical tillage

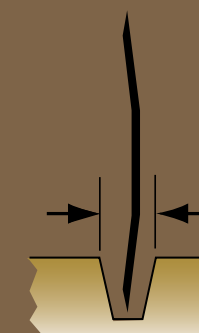
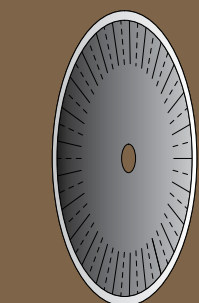

- Aggressiveness ↑↑↑
- Tillage practice **VERTICAL**
- Residue management ↑↑↑
- Soil penetration ↑↑↑
- Speed ↑↑↑
- Seedbed preparation ↑↑↑

No-Till Tillage

RADIALRAZOR™

Ideal lead coulters for a no-till planter

Patented edge design features a gradual rise and return of the wave edge pattern that sharply cuts through residue, creating a clean seed slot.

The RadialRazor is ideal as a lead coulters for a planter in a no-till practice. It makes a consistent, narrow planting slot with minimum soil disturbance, forming an optimum seed environment for uniform seed placement.

The RadialRazor is effective in wet or dry soils and requires lower horsepower for vertical penetration.

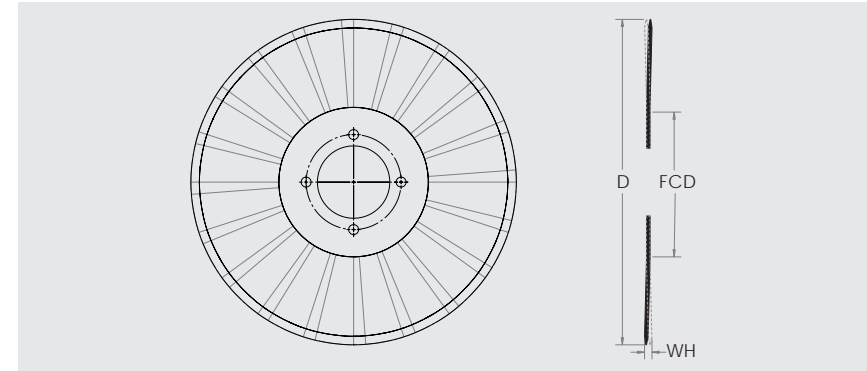

Ideal Lead Coulters for a No-Till Planter

Diameter		Thickness		Wave Height		FCD	
inches	mm	inches	mm	inches	mm	inches	mm
14	355	0.157	4	0.31	8	8.27	210
15	383	0.157	4	0.37	9.5	8.27	210
16	406	0.157	4	0.37	9.5	8.27	210
16	406	0.177	4.5	0.37	9.5	8.27	210
17	433	0.157	4	0.37	9.5	8.27	210
18	457	0.157	4	0.41	10.5	8.27	210
18	457	0.197	5	0.41	10.5	8.27	210
20	514	0.197	5	0.41	10.5	8.27	210



RADIALRAZOR™

Ideal lead coulters for both planting and fertilizer applications

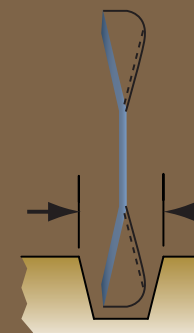
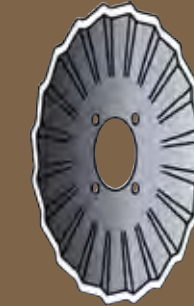

- Aggressiveness ↑↑↑
- Tillage practice **NO-TIL**
- Residue management ↑↑↑
- Soil penetration ↑↑↑
- Speed ↑↑↑
- Seedbed preparation ↑↑↑

Residue management

RESIDUERAZOR® EDGE

A five times sharper edge

Take a close look at the two disc blade edges. The one on the right side has the unique Ingersoll ResidueRazor® edge. The one on the left is an ordinary edge, the kind you'll find on many competitive blades.

With the ResidueRazor, we use carbide cutters to create an edge that's five times sharper than any ordinary blade.

This edge is ideal for genetically engineered corn, soybean, wheat or barley residue.

ResidueRazor blades are made from Ingersoll's own PURE™ professional grade steel – amazingly hard and flexible at the same time, helping make your concave discs perform better.

Residue Razor

Diameter	Thickness
Inches	mm
18	4/4.5/5/6/6.5
20	4/4.5/5/6/6.5
22	4/4.5/5/6/6.5
24	4/4.5/5/6/6.5

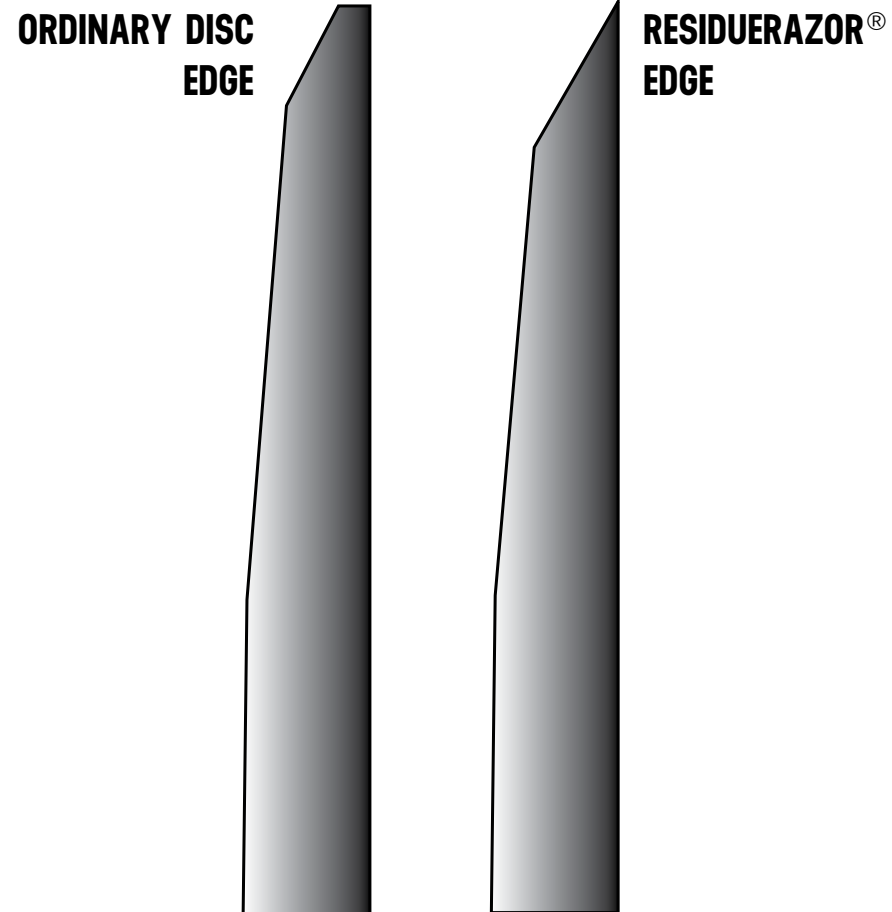
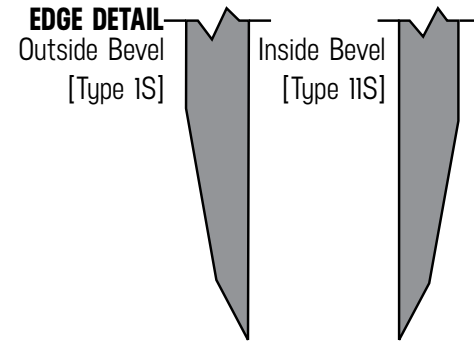

CONCAVE TILLAGE DISCS

Ingersoll provides today's producers with a complete line of concave tillage discs. Available only from Ingersoll!



GET THE EDGE

Conventional Tillage

PLAIN CONCAVE DISCS

Achieve high performance with your edge preference

Plain concave discs provide significant soil disturbance for tilling and inverting the soil, plus mixing the residue into the soil. They are maximum soil movers and can be used in all types of soil conditions.

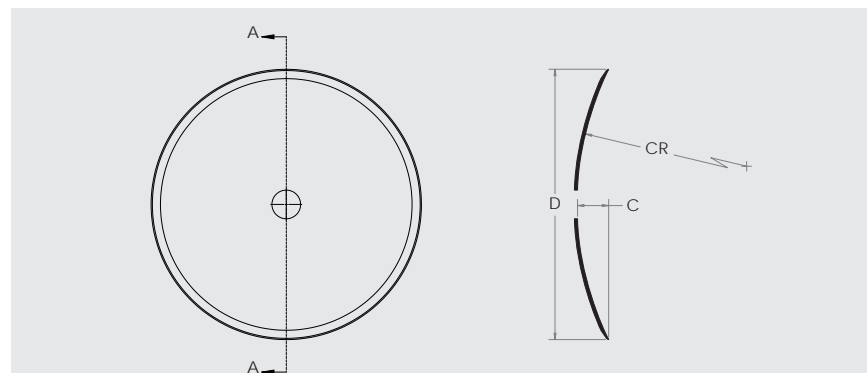

Plain & Notched Concave Disc Dimensions

Deep

Shallow

	Concavity Radius (CR)															
	540 mm		560 mm		620 mm		675 mm		710 mm		760 mm		840 mm		920 mm	
	Diam. mm	Concavity mm	Diam. mm	Concavity mm	Diam. mm	Concavity mm	Diam. mm	Concavity mm	Diam. mm	Concavity mm	Diam. mm	Concavity mm	Diam. mm	Concavity mm	Diam. mm	Concavity mm
9"			238	12												
12"			303	20.5												
14"			352	27												
16"			408	37	410	35										
18"			457	48	459	42							461	31	461	26
20"	504	59			508	53					511	41.5	514	38	515	34
22"	557	73			560	65	560	58.5			565	51	565	47	569	42
24"	604	88			611	78	615	69.5	617	66.5	618	63	620	57	625	47
26"	654	108			668	94.5	670	86.5	676.5	81	676	76			678	61
28"	699	127							722	95					734	73
30"									758	104.5			768	89	768	82.5
32"									820	125.5						

EDGE DETAIL

[Type 1S] Residue Razor Edge



Outside Bevel

[Type 1A]



[Type 1]



Inside Bevel

[Type 1I]



[Type 1IA]



[Type 1IS] Residue Razor Edge



PLAIN CONCAVE DISCS

Discs for tilling and inverting the soil

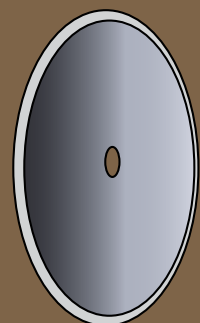

DEEP

SHALLOW

Aggressiveness



Aggressiveness



Tillage practice
CONVENTIONAL



Tillage practice
NO-TILL

Residue management



Residue management



Soil penetration



Soil penetration



Speed



Speed



Seedbed preparation



Seedbed preparation



As concavity increases, soil movement increases.

Conventional Tillage

NOTCHED CONCAVE DISCS

Achieve high performance with your edge preference

Notched concave discs provide a very aggressive cutting edge that is well-suited for soil penetration (*especially when the concavity of the disc is shallow*). These discs are also a good choice for residue management.

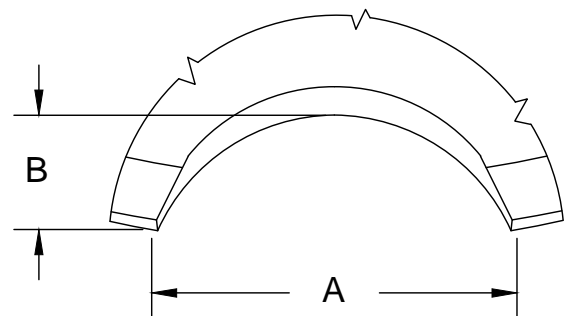

Notched Concave Discs

Diameter Inches	# Notches	A Inches	A mm	B Inches	B mm
16	8	3.11	79	1.14	29
18	9	3.11	79	1.14	29
20	10	3.11	79	1.14	29
22	10	3.11	79	1.14	29
24	10	3.11	79	1.14	29
26	10	3.54	90	1.57	40
28	10	3.54	90	1.57	40
30	10	3.54	90	1.57	40
32	10	3.54	90	1.57	40

EDGE DETAIL

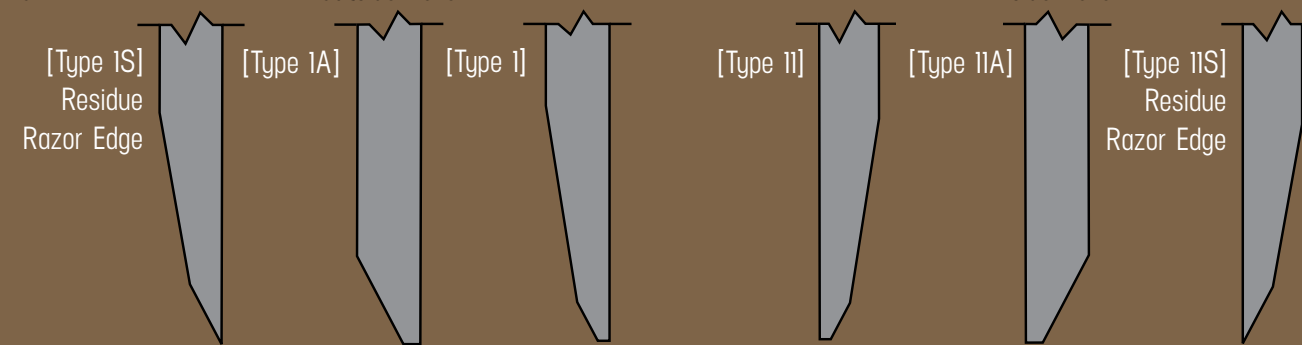

NOTCHED CONCAVE DISCS

Aggressive discs for tilling and inverting the soil

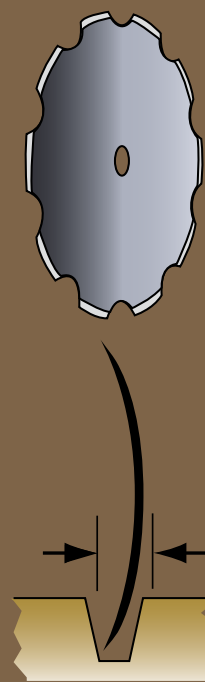

	DEEP	SHALLOW
Aggressiveness	↑↑↑	↑↑↑
Tillage practice	CONVENTIONAL	VERTICAL & CONVENTIONAL
Residue management	↑↑↑	↑↑↑
Soil penetration	↑↑↑	↑↑↑
Speed	↑↑↑	↑↑↑
Seedbed preparation	↑↑↑	↑↑↑

Vertical Tillage

PLAIN FLAT CENTER DISCS

Achieve high performance with your edge preference

Plain coulters are the perfect solution for when you want to cut through residue and penetrate the soil with minimal soil disturbance.

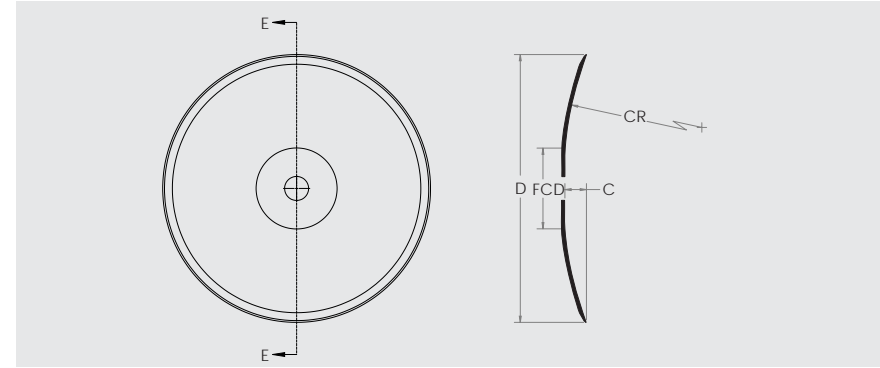
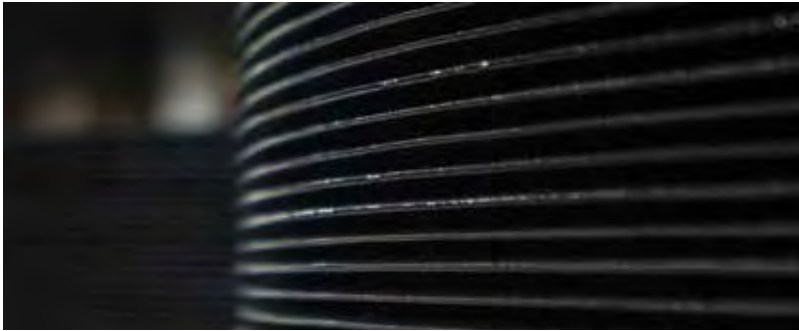

Plain & Notched Flat Center Disc Dimensions

Deep

Shallow

	Concavity Radius (CR)																	
	320 mm (FCD: 84 mm)		405 mm (FCD: 120.7 mm)		475 mm (FCD: 98.5 mm)		560 mm (FCD: 114mm)		620mm (FCD: 165mm)		620mm (FCD: 178mm)		710mm (FCD: 120 mm)		760mm (FCD: 185mm)		920mm (FCD: 185mm)	
	Dia mm	Conc mm	Dia mm	Conc mm	Dia mm	Conc mm	Dia mm	Conc mm	Dia mm	Conc mm	Dia mm	Conc mm	Dia mm	Conc mm	Dia mm	Conc mm	Dia mm	Conc mm
8"	201	13.8																
9"			237	12.5	237	12												
12"					302	22							303	13.5				
12.8"			323	29														
13"			335	32			327	19					325	16				
14"			347	34									353	19				
16"							408.5	33.5				410.5	31.75					
18"							457	48	460	36	460	36			463	28.5		
20"									515	40	508.5	45.5			514	36		
22"									567	51					566	45.5		
24"									613	71					614	58	625	46
26"															676	71	681	58.5

30 See page 28 for notch detail.

EDGE DETAIL

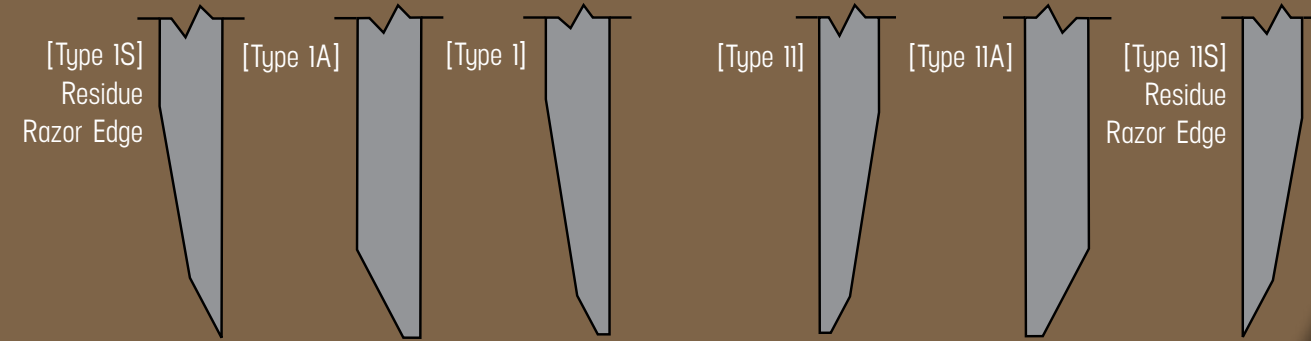

PLAIN FLAT CENTER DISCS

Cuts through residue and penetrates the soil

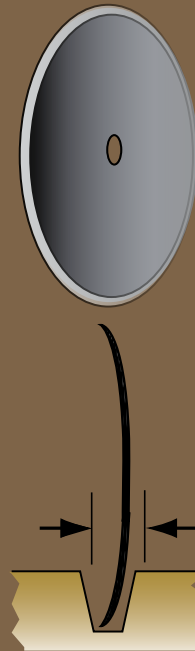

	DEEP	SHALLOW
Aggressiveness	↑↑↑	↑↑↑
Tillage practice	CONVENTIONAL	VERTICAL & CONVENTIONAL
Residue management	↑↑↑	↑↑↑
Soil penetration	↑↑↑	↑↑↑
Speed	↑↑↑	↑↑↑
Seedbed preparation	↑↑↑	↑↑↑

All Tillage Practices

ROLLABLE BORON CONCAVE DISCS

Edges can be renewed by rolling

Rollable boron discs enjoy the advanced properties of Ingersoll's exclusive boron alloy, yet the edges of these discs can be renewed by rolling, rather than sharpening. For farmers who use rolling equipment, these discs offer the best of both worlds.

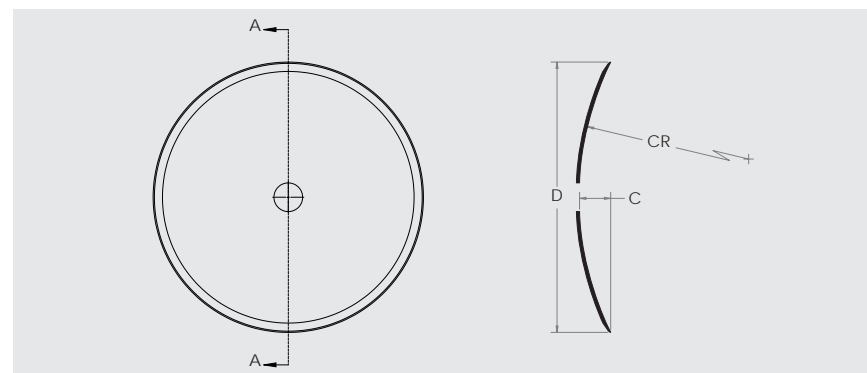

Rollable Boron Disc Blades - Plain

Diameter		Thickness	Concavity		Radius
inches	mm	mm	inches	mm	mm
18	461	6.5	1.02	26	920
20	515	6.5	1.33	34	920
22	560	6.5	2.5	65	620
22	569	6.5	1.65	42	920
24	611	6.5	3.1	78	620
24	618	6.5	2.48	63	760

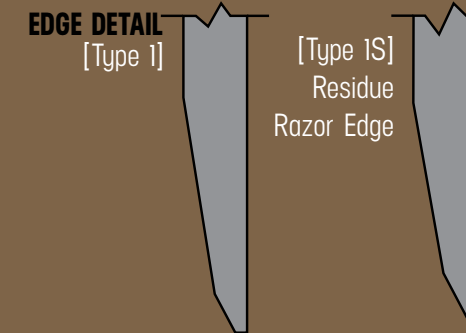

ROLLABLE BORON CONCAVE DISCS

Edges can be renewed by rolling

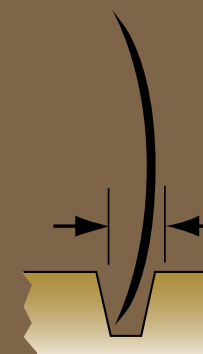
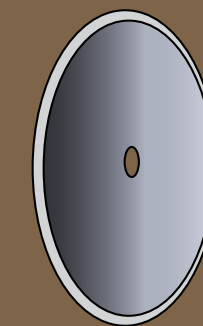

- Aggressiveness ↑↑↑
- Tillage practice ALL
- Residue management ↑↑↑
- Soil penetration ↑↑↑
- Speed ↑↑↑
- Seedbed preparation ↑↑↑

Conventional Tillage

3-SIDED CONCAVE DISCS

Typically used as a leveling disc at the end of a tillage tool

Two different types of notches can be applied. For curved or radiused notches, the maximum depth is 84 mm. In straight edge notches, the maximum depth achieved is 53 mm.

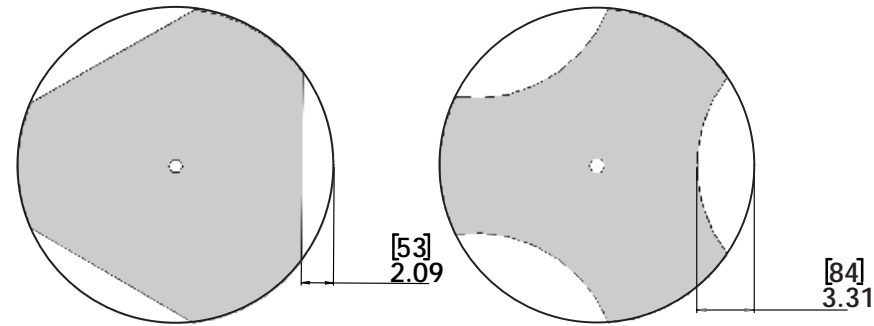

3-Sided Concave Disc Blades

Diameter	Thickness
inches	mm
16	4/4.5
18	3/4/4.5/5/6,5
20	4/5/6.5
22	5.0/6.0/6.5
24	6.0/6.5/8.0

3-sided discs are available in any full concave or flat back dimension.

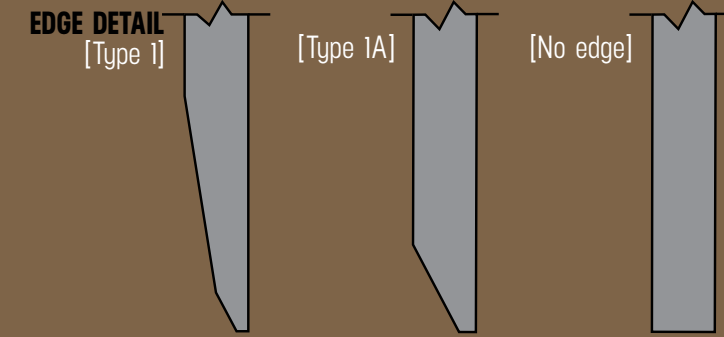

3-SIDED CONCAVE DISCS

Special purpose gang-end disc

- Aggressiveness ↑↑↑
- Tillage practice **CONVENTIONAL**
- Residue management ↑↑↑
- Soil penetration ↑↑↑
- Speed ↑↑↑
- Seedbed preparation ↑↑↑



Conventional Tillage

PLAIN AND NOTCHED DURAFACE DISCS

Special surface coating

The patented DuraFace process is a special surface coating that yields a disc nearly as hard as tungsten carbide but without the brittleness, nearly as corrosion-resistant as stainless steel but without the high price.



DuraFace™ Coating

DuraFace coating can be applied to all plain and notched discs, full concave or flat back.

Diameter	Thickness
inches	mm
24	6 / 6.5
26.5	6 / 6.5
28.5	6 / 6.5 / 8
30	8

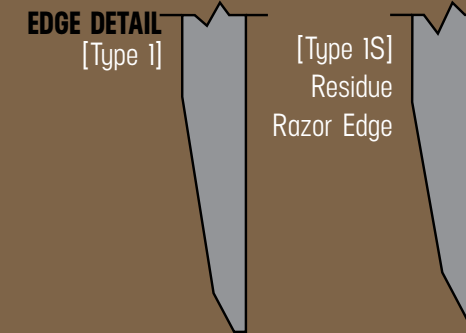

PLAIN and NOTCHED DURAFACE™ DISCS

Long-lasting use in abrasive soils

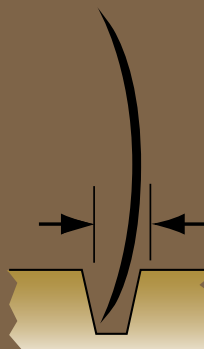
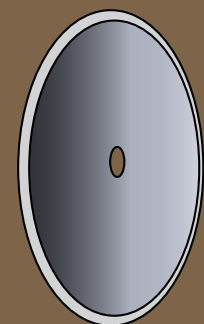

PLAIN	NOTCHED
Aggressiveness ↑↑↑	Aggressiveness ↑↑↑
Tillage practice CONVENTIONAL	Tillage practice CONVENTIONAL
Residue management ↑↑↑	Residue management ↑↑↑
Soil penetration ↑↑↑	Soil penetration ↑↑↑
Speed ↑↑↑	Speed ↑↑↑
Seedbed preparation ↑↑↑	Seedbed preparation ↑↑↑



COULTERS

Ingersoll provides today's producers with a complete line of coulters. Available only from Ingersoll!



GET THE **EDGE**

All Tillage Practices

Plain Coulters - Flat & Notched

For all types of soil conditions

Plain coulters are the perfect solution for when you want to cut through residue and penetrate the soil with minimal soil disturbance. Notched coulters are used when a more aggressive disc is needed.

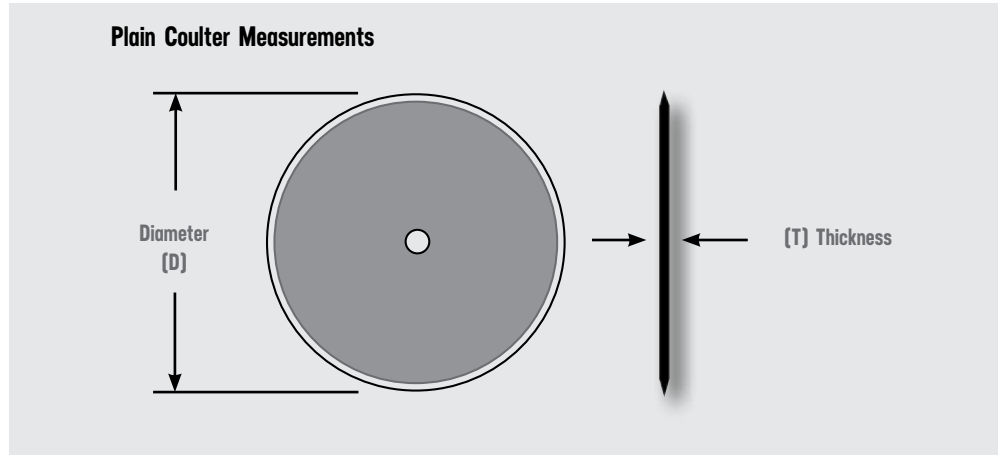
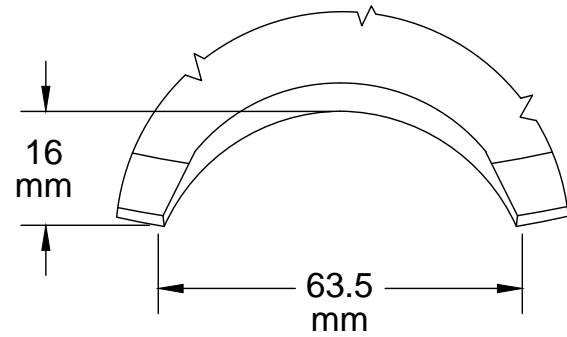

Plain Coulters - Flat & Notched

Diameter		Thickness	Typical # Notches
inches	mm	mm	
8	204	2.5	NA
9	239	2.5/3.5	NA
12	306	2.5/3	9/10
13	330	3	10
13.5	344	3.5	10
14	356	2.5/3/3.5/4/5	9/10/13
15	381	3/3.5/4/5	10
15.8	401	3.5/4/4.5	6
16	410	3.5/4/4.5/5/6.5	6/8/10
17	430	4/4.5	13
18	460	4/4.5/5/6.5	9
18	467	3/3.5/4/4.5/5/6/6.5	9
20	520	4.5/5/6/6.5	13
22	576	4.5/5/6.5	10
24	632	4.5/5/6/6.5	10

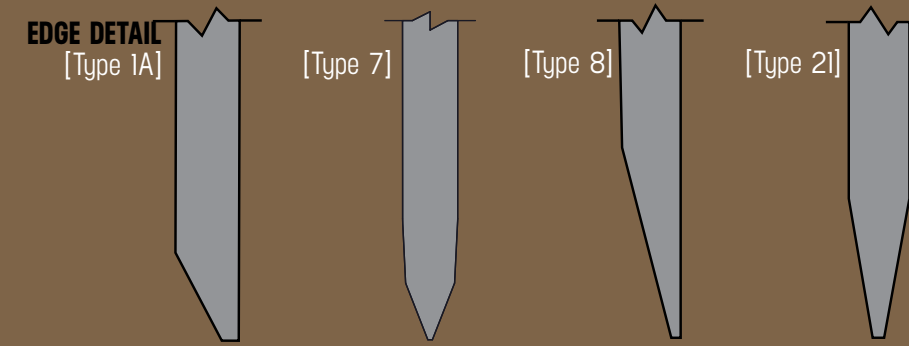

FLAT and NOTCHED COULTERS

Good cutting performance with minimal soil disturbance

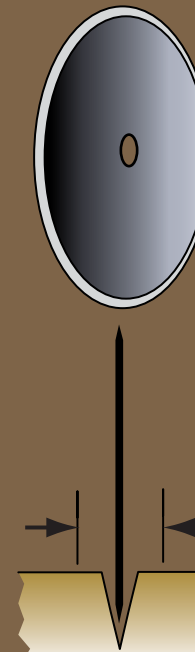

- Aggressiveness ↑↑↑
- Fertilizer ↑↑↑
- Soil conditions ALL
- Tillage practice ALL
- Residue management ↑↑↑
- Placement DEEP
- Speed ↑↑↑
- Soil tilth EXTRA FINE

All Tillage Practices

8 WAVE COULTERS

Aggressive soil disturbance

8 wave coulters are designed to cut through residue while providing greater soil disturbance. Ideal for dry, sandy or heavy soils and can be used at medium or high speed.

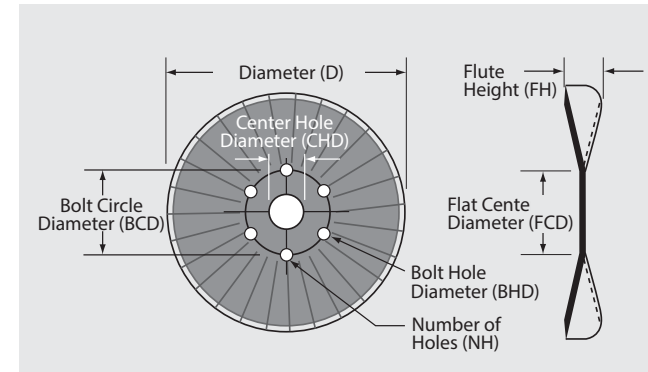

8 Wave Coulters

FCD: 7" (178 mm)

Diameter		Thickness	Flute Height	
inches	mm	mm	inches	mm
Shallow				
14	364	4/4.5	0.75	19
15	378	4/4.5	0.81	20.5
16	401	4/4.5	0.87	22
17	448	4/4.5	1.02	26
18	460	4/4.5	1.04	26.5
22	560	5/6.5	2.28	58
Deep				
15	373	4.5	1.3	33
17	439	4/4.5	1.77	45
18	446	4.5/5	1.81	46
18	446	4/4.5/5	2.56	65
20	506	4.5/5/6	2.2	56
22	555	5/6.5	2.56	65

EDGE DETAIL
[Type 21]



8 WAVE COULTERS

Aggressive cutting for residue management and greater soil disturbance

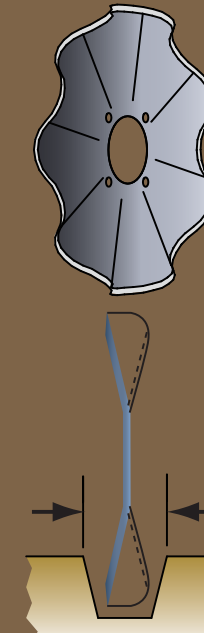

- Aggressiveness ↑↑↑
- Fertilizer ↑↑↑
- Soil conditions **DRY, SANDY, HEAVY**
- Tillage practice **ALL**
- Residue management ↑↑↑
- Placement **SHALLOW**
- Speed ↑↑↑
- Soil tilth **COARSE & MEDIUM**

All Tillage Practices

13 WAVE COULTERS

Greater soil disturbance and tilling action

Wavy and fluted coulters are designed to help manage residue by cutting through old crop and opening a strip in the soil. 13 Wave coulters have good tilling action, achieving a fine soil tilth at all speeds, in dry, sandy and heavy soil conditions.

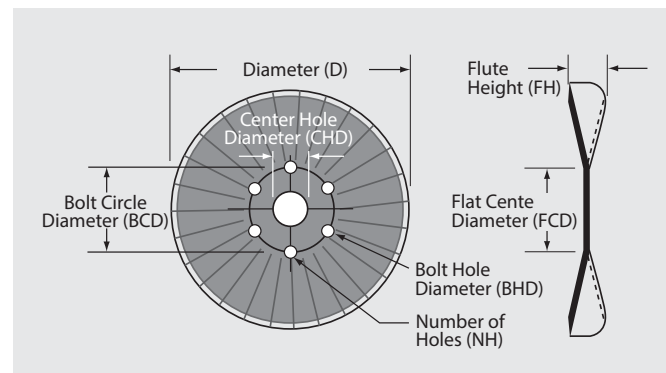

13 Wave Coulters

FCD: 8" (203 mm)

Diameter		Thickness	Flute Height	
inches	mm	mm	inches	mm
13	330	3	0.45	11.5
13.5	344	3.5	0.51	13
14	364	4.5	0.57	14.5
15	381	4	0.61	15.5
16	401	4/4.5	0.67	17
17	428	4/4.5/5	0.83	21
17.6	446	4/4.5	0.85	21.5
18	458	4/4.5/5	0.90	23
20	516	4/5/6/6.5	1.06	27
22	571	4.5/5/6.0/6.5	1.22	31

EDGE DETAIL
[Type 21]



13 WAVE COULTERS

Second in a series for residue management and soil disturbance

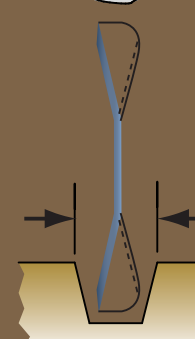
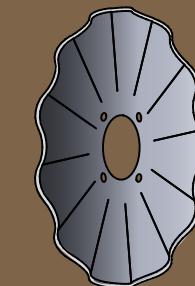

- Aggressiveness
 ↑↑↑
- Fertilizer
 ↑↑↑
- Soil conditions
DRY, SANDY, HEAVY
- Tillage practice
ALL
- Residue management
 ↑↑↑
- Placement
SHALLOW
- Speed
 ↑↑↑
- Soil tilth
COARSE, MEDIUM & FINE

All Tillage Practices

25 WAVE COULTERS

Medium tillage action to achieve extra fine tilth

25 Wave coulters have a medium tillage action and are designed to create an extra fine tilth and exceptional seedbed. With moderate cutting and penetration, this coulters is ideal for dry, sandy and heavy soils, and can be used at any speed.

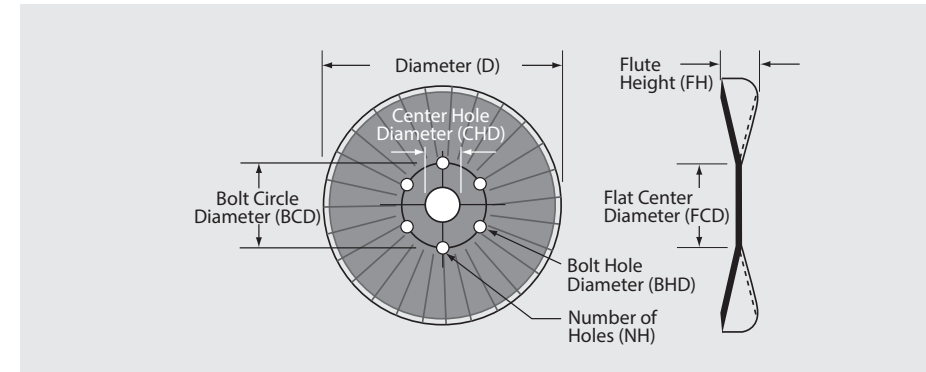

25 Wave Coulters

Diameter		Thickness	FCD		Flute Height	
inches	mm	mm	inches	mm	inches	mm
13	328	3	9.4	240	0.55	14.5
14	364	4	9.4	240	0.55	14.5
15	373	4/4.5	9.4	240	0.55	14.5
16	401	4/4.5	11	279	0.63	15
18	446	4/4.5	11.8	298	0.63	15
20	518	4/4.5	11.8	298	0.63	15
22	572	4.5/5.0	11.25	286	0.63	15

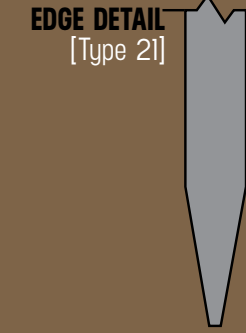

25 WAVE COULTERS

Aggressive cutting for residue management with reduced soil disturbance

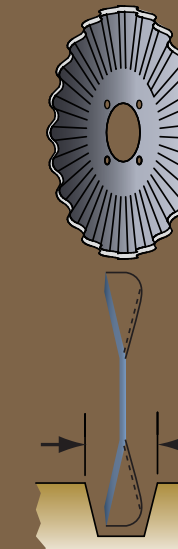

- Aggressiveness ↑↑↑
- Fertilizer ↑↑↑
- Soil conditions **DRY, SANDY, HEAVY**
- Tillage practice **ALL**
- Residue management ↑↑↑
- Placement **SHALLOW**
- Speed ↑↑↑
- Soil tilth **EXTRA FINE**

Reduced Tillage

RIPPLED AND BUBBLE COULTERS

Minimum soil disturbance

Rippled coulters offer excellent penetration and cutting with a minimum of soil disturbance. They are good for a wide variety of soil conditions.

Bubble coulters are well-suited for fields with light residue where minimum stirring of the soil is desired.

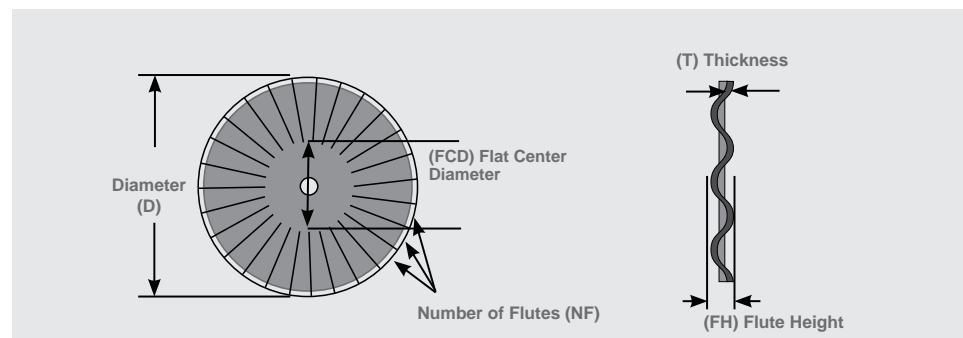

Rippled Coulters

Diameter		Thickness	FCD		Waves	Flute Height	
inches	mm	mm	inches	mm	#	inches	mm
15	381	3.5	12.25	311	50	0.16	4
16	401	4	12.25	311	50	0.16	4
17	430	3.5/4/4.5	12.25	311	50	0.16	4
17.5	447	4.5	12.25	311	50	0.16	4
18	460	4	12.25	311	50	0.16	4
18	454	4.5	14.25	362	60	0.27	7
20	520	4/4.5	14.25	362	60	0.31	8
20	506	4.5	14.25	362	60	0.31	8
22	565	4.5	16.77	426	60	0.31	8
22.5	576	4.5/5	16.69	424	60	0.31	8

36 Bubble Coulters

Diameter		Thickness	FCD		Waves	Flute Height	
inches	mm	mm	inches	mm	#	inches	mm
15	380	4.5	8.27	210	36	0.787	20
16	401	4	8.27	210	36	0.787	20

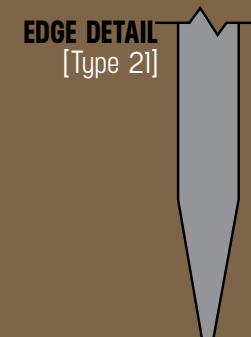

RIPPLED and BUBBLE COULTERS

Residue management with a minimum of soil disturbance

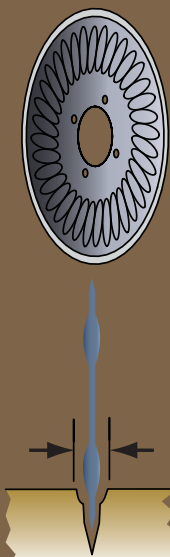

RIPPLED		BUBBLE
Aggressiveness	↑↑↑	↑↑↑
Fertilizer	↑↑↑	↑↑↑
Soil conditions	ALL	DRY, SANDY
Tillage practice	NO-TIL & REDUCED TILL	REDUCED TILL & CONVENTIONAL
Residue management	↑↑↑	↑↑↑
Placement	SHALLOW	SHALLOW
Speed	↑↑↑	↑↑↑
Soil tilth	MEDIUM	COARSE & MEDIUM



Disc Weights

Diameter	Thickness	Weight	
		lbs	kgs
inches	mm		
8	2	1.19	0.54
8	2.5	1.37	0.62
9	2.5	1.72	0.78
9	3	1.98	0.9
9	3.5	2.64	1.2
10	2.5	2.07	0.94
12	2.5	2.7	1.22
12	3	3.3	1.5
12.5	2.5	3.05	1.38
12.5	3	3.93	1.78
12.75	3	4.14	1.88
13	2.5	3.42	1.55
13	3	4.33	1.96
13	3.5	4.95	2.25
13	4.5	5.75	2.61
13.5	2.5	3.84	1.74
13.5	3	4.53	2.05
13.5	3.5	5.17	2.35
13.5	4	5.9	2.68
14	2.5	4.05	1.84
14	3	5.13	2.33
14	3.5	5.37	2.44
14	4	5.72	2.59
14	5	7.25	3.29
15	3.5	6.75	3.06
15	4	7.65	3.47
15	4.5	8.22	3.73

Diameter	Thickness	Weight	
		lbs	kgs
inches	mm		
15	5	8.94	4.06
16	3	6.15	2.79
16	3.5	6.95	3.15
16	4	7.85	3.56
16	4.5	8.35	3.79
16	5	10.2	4.63
16	6.5	12.75	5.78
17	3.5	8.3	3.76
17	4	9.2	4.17
17	4.5	10.82	4.91
17	5	11.07	5.02
18	3	7.8	3.54
18	3.5	9.61	4.36
18	4	10.01	4.54
18	4.5	11.44	5.19
18	5	13.3	6.03
18	6	14.8	6.71
18	6.5	17.85	8.1
20	3.5	12.5	5.67
20	4	13.85	6.28
20	4.5	15.75	7.14
20	5	17.45	7.92
20	6	20.6	9.34
20	6.5	22	9.98
22	4.5	19.7	8.94
22	5	21.4	9.71
22	6	25.3	11.48
22	6.5	27.5	12.47

Diameter	Thickness	Weight	
		lbs	kgs
inches	mm		
22	7	29.5	13.38
22	8	33.5	15.2
24	4.5	22.2	10.07
24	5	25.9	11.75
24	6	28.3	12.84
24	6.5	30.4	13.79
24	8	40.5	18.37
26	5	30.6	13.86
26	6	35.2	15.97
26	6.5	37.6	17.06
26	8	48.6	22.04
28	6	43.2	19.57
28	6.5	46.4	21.05
28	8	54.5	24.72
28	9	63.5	28.8
28.5	6	45.7	20.74
28.5	6.5	48.3	21.91
28.5	8	57.6	26.13
28.5	9	66.5	30.16
30	6	48.3	21.91
30	8	60.6	27.49
30	9	68.5	31.07
30	10	75.4	34.2
32	8	73.6	33.38
32	10	90.1	40.88
32	12	111	50.35
36	12	139	63.05
36	12.5	141.2	64.07

PLANTING and SEEDING DISCS

Products for ideal seedbed preparation, accurate seed placement and strong emergence.



GET THE EDGE

Planting and Seeding

ASSEMBLED OPENERS

Adapted to your needs

Ingersoll offers the industry's most reliable openers. Made with an exclusive alloy of boron steel, they offer unsurpassed performance in the field.

Ingersoll's assembled openers can be provided with heavy-duty bearings and hubs for no-till planting and seeding applications.



Assembled Openers

Diameter		Thickness mm	Fits Shaft	Remarks
Inches	mm			
8	203	2.5	5/8"	Standard bearing
12	303	2.5	5/8"	Cast bearing housing with double row bearing
12	303	3.0	5/8"	Double row waterpump
12	303	3.0	3/4"	Double row waterpump
13.5	343	3.0	5/8"	Standard bearing
13.5	343	3.5	5/8"	Left and right hand version, standard 205 bearing
13.5	343	4.0	5/8"	Standard bearing
14	356	2.5	5/8"	Standard bearing
14	356	3.5	5/8"	Standard bearing left and right hand
14	356	3.5	5/8"	Heavy duty bearing left and right hand, standard blade
15	381	3.0	5/8"	Standard bearing
15	381	3.5	3/4"	Standard bearing. Heavy duty bearing with heavy duty hub
15	381	3.5	5/8"	Standard bearing with plastic cap. Double row bearing with metal cap
15	381	4.0	5/8"	Cast bearing housing with double row bearing
15	381	4.0	20mm	Cast bearing housing with double row bearing
15	381	4.0	5/8"	Single Row
15.8	401	3.5	3/4"	Heavy duty bearing with heavy duty hub
18	457	4.0	3/4"	Lead and trailing disc

ASSEMBLED OPENERS

Assembled openers are available with standard bearings or specially designed heavy-duty bearings. Examples shown here are some of the hubs available.



Planting and Seeding

PLAIN OPENERS AND COVERING DISC ASSEMBLIES

Slight concavity openers

Openers are manufactured to the requested concavity to achieve the optimum desired seedbed. Made with an exclusive alloy of boron steel, they offer unsurpassed performance in the field.

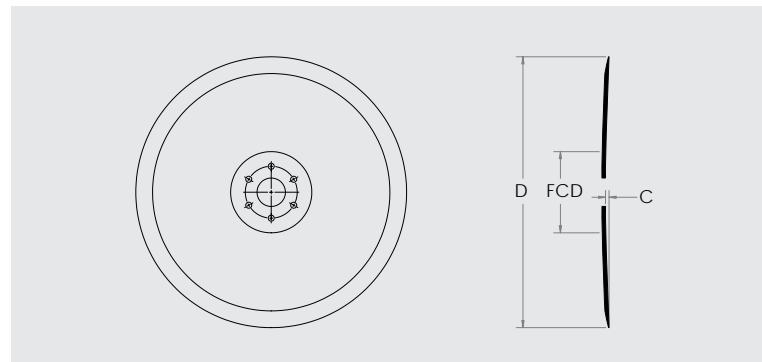

Plain Openers

Diameter		Thickness	Concavity	
inches	mm	mm	inches	mm
9	231	3.0	0.031	0.8
12	306	2.5/3.5	0.039	1.0
12.5	321	2.5/3.0/3.5	0.047	1.2
13	330	2.5/3.0	0.055	1.4
13.5	344	2.5/3.0/3.5/4.0	0.063	1.6
14	356	2.5/3.5/4.0/4.5/5.0	0.071	1.8
14	356	3.0	0.071	1.8
15	381	3.0/3.5/4.0/4.5	0.075	1.9
15.8	401	3.5	0.079	2.0
16	410	3.0/4.0	0.083	2.1
18	460	4.0	0.094	2.4

Covering Disc Assemblies

Diameter		Thickness		Fits Shaft
Inches	mm	Inches	mm	
8	203	0.08	2.0	5/8"
8	203	0.1	2.5	5/8"

EDGE DETAIL
[Type 1A]

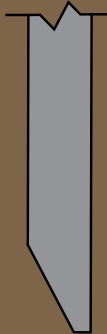

[Type 8]

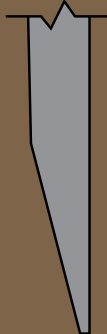

[Type 9]

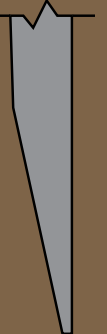

PLAIN OPENERS and COVERING DISC ASSEMBLIES



Tillage Maintenance

EDGE CARE™ PLUS “on-the-gang” DISC SHARPENER
50% improved sharpening time

- Sharpen Ingersoll disc blades right on the gang, or individual hub mounted disc
- Simple design allows quick and easy setup
- Edge Care™ Plus cold sharpening technology extends disc blade life
- Unique Edge Care Plus inside ground bevel profile does not reduce the diameter of the disc blade
- Edge Care Plus system insures that the disc maintains factory approved levels of hardness and ductility
- Average sharpening time is 2 to 3 minutes per disc (24" disc)
- Extra sharpening wheel included
- Made in USA

**EDGE CARE™ PLUS**
“on-the-gang”
DISC SHARPENER

Restore your
Ingersoll disc blades to
factory-approved sharpness.

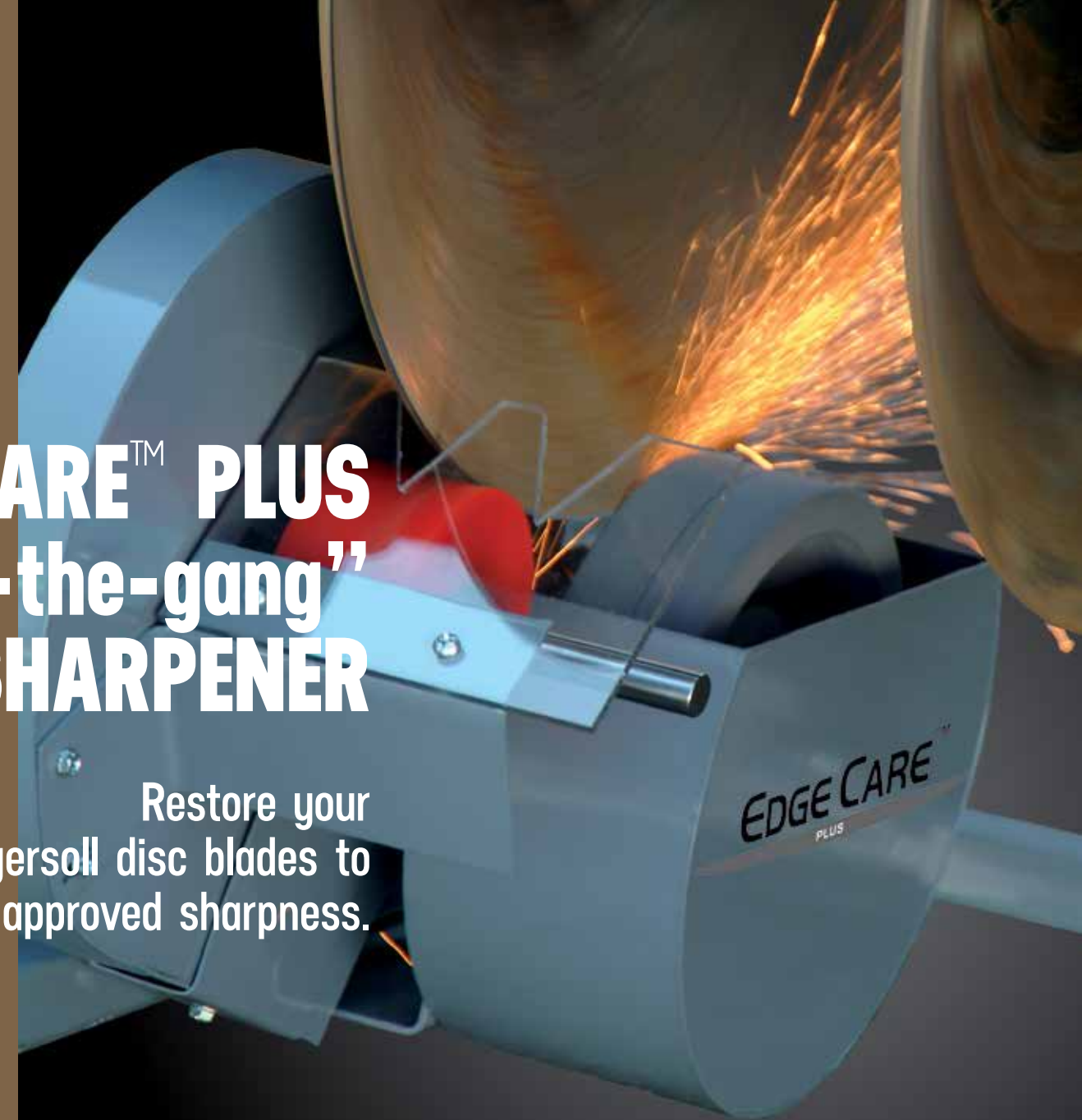

Conventional Tillage

SOILRIPPER TILLAGE POINTS

Extra high strength steel

Ingersoll's new SoilRipper™ tillage points feature a robust design and superior fine grain chromium-carbide steel to withstand the most challenging soil conditions, providing the best overall value choice.

FEATURES

- Patented design
- More robust design with extra high strength steel for longer service life
- Wing and nose surface geometry generates maximum soil fracturing while reducing draft loads
- As they wear, SoilRipper points maintain their ability to penetrate the toughest soil conditions
- Wear feature protects mounting hardware
- Ideal for high speed compaction-busting tillage applications

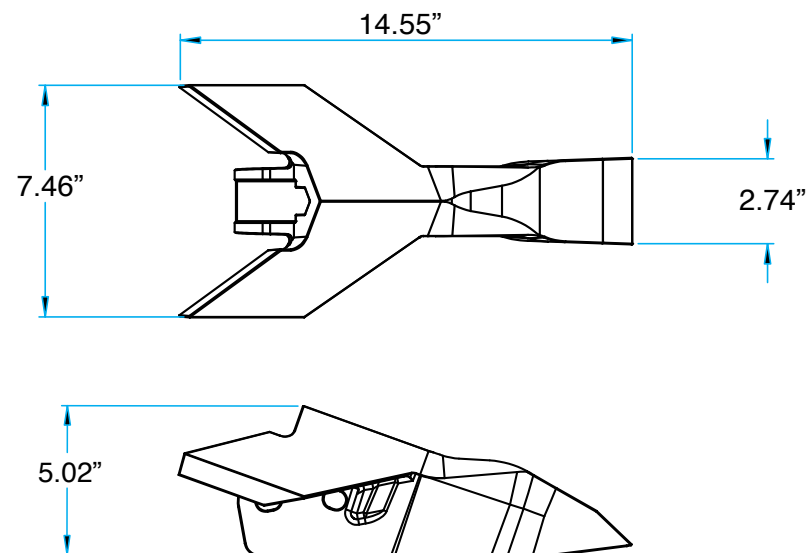

SPECIFICATIONS

- Solid one-piece cast for extreme durability with super hard steel
- Formed from fine grain chromium-carbide steel
- Rockwell hardness score of 48-50 Rc
- 7.5" winged SoilRipper point designed for a 1.25" shank width
- 24 lbs.
- Designed to fit Case IH, DMI, Krause and John Deere equipment

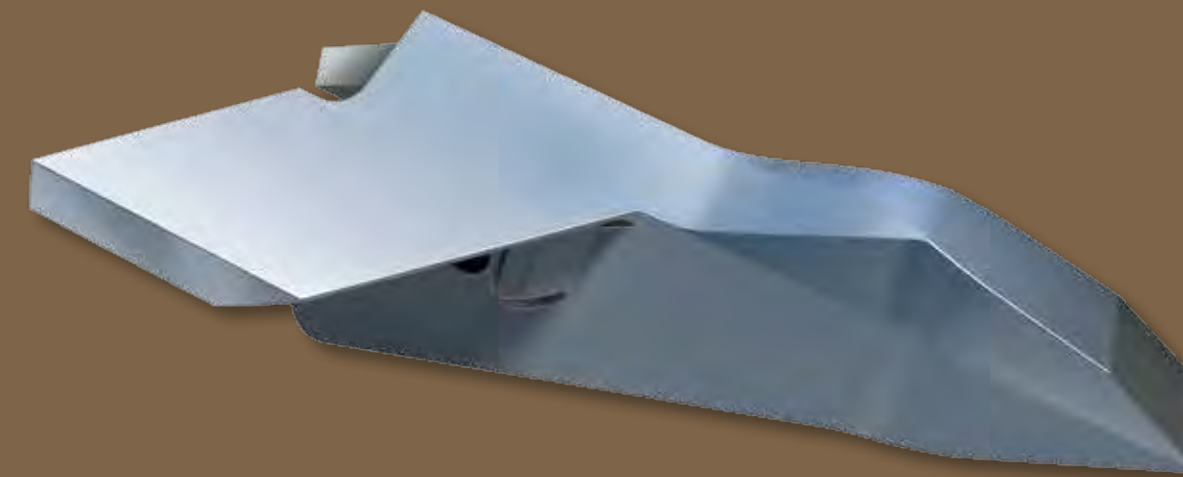

SOILRIPPER™ TILLAGE POINTS

Maximum soil fracturing with reduced draft load

Plain Concave, Rollable Boron and DuraFace™

Certain sizes are available without a center hole. Contact Customer Service.

ITG Hole Pattern	Hole Pattern Order Number	Spec	Fits Axle Type	Fits Axle Sizes			
	10	DS1	Square or Round	7/8" Square	1" Square	1" Round	
	11	DS2	Square or Round	1" Square	1-1/8" Square	1-1/8" Round	
	12	DS3	Square or Round	1-1/8" Square	1-1/4" Square	1-1/4" Round	
	13	DS9	Square or Round	1-1/4" Square	1-1/2" Square	1-1/2" Round	
	14	DS4	Square or Round	1-1/2" Square	1-3/4" Square	1-3/4" Round	
	49	R51	Round	15/16" Round			
	15	R1	Round	1" Round			
	16	R2	Round	1-1/8" Round			
	17	R3	Round	1-1/4" Round			
	18	R4	Round	1-1/2" Round			
	19	R46	Round	1-3/4" Round			
	20	R5	Round	1-3/4" Round			
	21	R6	Round	2" Round			
	57	113	Round	2-3/16" Round			
	22	R6.5	Round	2-1/4" Round			
23	R7	Round	2-1/2" Round				
	24	SQ1	Square	1" Square			
	25	SQ1.5	Square	1-1/4" Square			
	26	SQ2	Square	2-3/8" Square			
	27	SR1	Square or Round	7/8" Square	1" Round		
	28	SR2	Square or Round	1" Square	1-1/8" Round		
	29	SR3	Square or Round	1-1/8" Square	1-1/4" Round		
	30	SR4	Square or Round	1-1/4" Square	1-1/2" Round		
	31	SR4.5	Square or Round	1-1/2" square	1-5/8" Round		
	32	SR5	Square or Round	1-1/2" Square	1-3/4" Round		
	33	SR6	Square or Round	1-3/4" Square	2" Round		
	34	SR7	Square or Round	2-1/4" Square	2-1/2" Round		
		35	CL1	Square or Round	7/8" Square	7/8" Round	
		36	CL2	Square or Round	1" Square	1" Round	
37		CL3	Square or Round	1-1/8" Square	1-1/8" Round		
38		CL4	Square or Round	1-1/4" Square	1-1/4" Round		
39		CL5	Square or Round	1-1/2" Square	1-1/2" Round		
50		CL41	Square	1.58"/40mm Square			
40		CL6	Square or Round	1-3/4" Square	1-3/4" Round		
41		CL7 / CL59	Square or Round	2-1/4" Square	2-1/4" Round		

Hole Configurations

Hole Configuration	Cluster Hole Order No.	Used on	Shape	Center Hole		Bolt Circle Dia.		Bolt Holes	Bolt Hole Dia.	
				Inches	MM	Inches	MM		Inches	MM
	51	IH older style, others	Rectangle	0.949 x 1.29	23.6 x 32.8	3.25	82.6	6	0.34	8.7
	52	CNH	Round	1.50	38.1	4.50	114.3	4	0.53	13.5
	57	BushHog, Kelly, Pearman	Round	2.53	64.3	3.63	92.2	4	0.41	10.3
	59	Kongskilde, Martin	Round	3.00	76.2	4.00	101.6	4	0.41	10.3
	62	Agco	Round	3.17	80.5	4.75	120.7	4	0.47	12.0
	69	K-Hart, Kinze, Kuhn-Krause, PCR Rydal Salford, Whalen, Wilcox, Yetter	Round	3.99	101.3	5.25	133.3	4	0.53	13.5
	74	CNH	Round	1.50	38.1	4.00	101.6	4	0.61	15.4
	76	CNH	Round	2.68	68.0	4.25	108.0	4	0.53	13.5
	78	Landoll, Mandako, Morris, Sunflower Tebben, Thurston, Unverferth, Wilrich, Yetter, Amako	Round	3.66	92.9	5.00	127.0	4	0.53	13.5
	80	Komia, Needham	Round	3.03	77.0	4.41	103.3	4	0.41	10.3
	81	Agco, CNH, Harriston, Regier, Sunflower	Round	2.50	63.5	4.00	101.6	4	0.53	13.5
	84		Round	2.70	68.3	4.25	108.0	4	0.41	10.3
	86	Agco, Bourgault	Round	3.64	92.5	5.00	127.0	4	0.70	17.9
	87	Argis, CNH, Needham	Round	3.41	86.6	4.42	112.3	4	0.53	13.5
	119	Affordable, Agco, Amity, Bourgault, CNH, Crustbuster DSI, Kelly, Key Adventures, Wilrich	Round	3.64	92.5	5.00	127.0	4	0.56	14.3
121	Agco	Round	3.50	88.9	5.00	127.0	4	0.56	14.3	
122	CNH, Kongskilde	Round	3.19	81.0	1.19	106.5	4	0.42	10.7	
125	Agco, Salford	Round	3.97	100.8	5.25	133.3	4	0.53	13.5	
	58	Agco, Crustbuster	Round	1.37	34.9	3.00	76.2	5	0.33	8.3
	63	Agco, Amaco, Argis, Brillion, CNH, Disc Pro ETS, Kuhn-Krause, Promachine, Salford, Schulte, Sunflower, Wilcox	Round	4.10	104.1	5.50	139.7	5	0.53	13.5
	79	Amaco, Great Plains, Power Farming	Round	2.40	61.0	4.45	113.0	5	0.51	13.0
	88	CNH, Kearney	Round	2.56	65.1	3.54	90.0	5	0.36	9.1
	91	Amity, Crustbuster, H&S	Round	1.37	34.9	3.00	76.2	5	0.33	8.3
	109	Alamo, Argis, Kearney	Round	2.14	54.4	4.72	131.1	5	0.52	13.1
	114	CNH	Round	4.08	103.6	5.50	139.7	5	0.53	13.5
	53	Agco, Alamo, Argis, CNH, Kinze	Round	2.02	51.2	3.50	89.0	6	0.41	10.3
	55	Argis, CNH, SMA, Til-Tech, Unverferth	Round	3.77	95.7	5.00	127.0	6	0.41	10.3
	60	K-Hart	Round	1.92	48.8	4.31	109.5	6	0.33	8.3
61	Truax	Round	1.44	36.5	3.13	79.4	6	0.27	6.8	
64	South American Product	Round	1.58	40.0	3.78	96.0	6	0.28	7.0	
66	South American Product	Round	2.44	62.0	3.62	92.0	6	0.43	11.0	
67	South American Product	Round	2.68	68.0	4.14	105.0	6	0.34	8.6	
68	South American Product	Round	2.95	75.0	4.53	115.0	6	0.35	9.0	
70	South American Product	Round	2.95	75.0	4.53	115.0	6	0.41	10.5	
71	South American Product	Round	3.15	80.0	4.53	115.0	6	0.34	8.6	

Hole Configurations

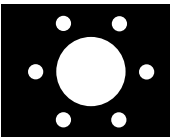
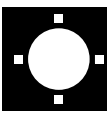
Hole Configuration	Cluster Hole Order No.	Used on	Shape	Center Hole		Bolt Circle Dia.		Bolt Holes	Bolt Hole Dia.	
				Inches	MM	Inches	MM		Inches	MM
	72	South American Product	Round	3.15	80.0	4.53	115.0	6	0.43	11.0
	73	South American Product	Round	4.84	123.0	6.02	153.0	6	0.34	8.6
	77	CNH, Hiniker	Round	1.73	43.9	2.50	63.5	6	0.27	6.8
	82	Kelly	Round	1.77	45.0	2.85	73.0	6	0.10	23.0
	83	Agco, Agri-Phyto, CNH, Crustbuster	Round	2.03	51.5	3.38	85.8	6	0.41	10.3
	90	Agco, CNH, Landoll, Salford	Round	1.50	38.1	3.00	76.2	6	0.37	9.5
	92	Duratech	Round	1.48	37.7	5.00	127.0	6	0.55	13.9
	93	Agco, CNH, Stroble	Round	1.93	49.0	2.87	71.8	6	0.33	8.3
	94	Agco, Amaco	Round	1.60	40.6	3.50	89.0	6	0.34	8.7
	96	Kuhn-Krause, Schaffert	Round	1.76	44.8	3.00	76.2	6	0.34	8.7
	97	Agco, Amaco, Artsway, Bourgault, CNH, Groff, Kearney, Kinze, Landoll, Yetter	Round	1.19	30.2	2.88	73.0	6	0.27	6.8
	98	Agco, Argis, Duratech, Kelly, Kinze, Kuhn-Krause Monosem, Precision Planting, Sustain Ag	Round	1.58	40.1	2.88	73.0	6	0.27	6.8
	99	Bourgault, CNH	Round	1.16	29.4	2.68	68.0	6	0.28	7.1
	100	CNH, Strobel	Round	1.16	29.4	2.50	63.5	6	0.27	6.8
	101	Burch	Round	2.08	52.8	2.97	75.4	6	0.34	8.7
	102	Kuhn-Krause	Round	1.58	40.1	2.78	69.8	6	0.22	5.6
	103	Agco	Round	1.56	39.7	2.78	69.8	6	0.24	6.0
	104	Agco, Kuhn- Krause	Round	1.77	44.9	3.00	76.2	6	0.28	7.1
	105	Agco	Round	1.63	41.3	2.50	63.5	6	0.27	6.8
	106	Becknell, CNH, Morris	Round	1.39	35.3	2.50	63.5	6		
107	Agco, Amity, CNH, Ditch Witch, Kuhn-Krause	Round	1.50	38.1	3.00	76.2	6	0.27	6.8	
108	Rain Flo	Round	1.50	38.1	4.25	108.0	6	0.41	10.3	
110	Noresman	Round	1.50	38.0	3.78	95.9	6	0.51	13.0	
118	Sustain Ag	Round	2.95	75.0	2.95	104.8	6	0.51	13.0	
124	Argis, Reiger, Unverferth	Round	3.81	96.7	5.00	127.0	6	0.41	10.3	
127	Agco, Monosem	Round	1.25	31.8	3.25	82.6	6	0.27	6.8	
129	CNH	Round	1.39	35.2	2.50	63.5	6	0.27	6.8	
130	Amity, Argis, Bourgault, BSB, CNH, Ditch Witch, Salford	Round	1.58	40.0	2.87	73.0	6	0.28	7.1	
131	Amity, CNH, Salford	Round	1.58	40.2	2.87	73.0	6	0.35	8.8	
132	CNH, Salford, Seedhawk	Round	1.58	40.0	3.00	76.2	6	0.34	8.5	
Round center hole with 4 square bolt holes 	54	Ag Synergy, Yetter	Round	3.97	100.8	5.25	133.4	4 Square Holes	0.53	13.5
	56	CNH, Unverferth	Round	1.78	45.2	5.00	127.0	4 Square Holes	0.53	13.5
	75	CNH, DSI	Round	2.50	63.5	5.00	127.04	4 Square Holes	0.53	13.5

Hole Configurations

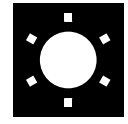
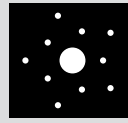
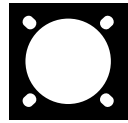
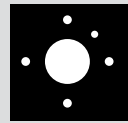
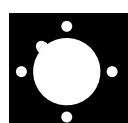
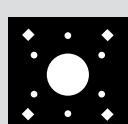
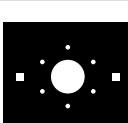
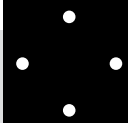
Hole Configuration	Cluster Hole Order No.	Used on	Shape	Center Hole		Bolt Circle Dia.		Bolt Holes	Bolt Hole Dia.	
				Inches	MM	Inches	MM		Inches	MM
Round Center hole with 6 square bolt holes 	65	South American Product	Round	1.97	50.0	3.78	96.0	6 Square Holes	0.28	7.0
Round Center hole with 2 rings of 5 Rd. blt. holes 	85	Agco, Agri-Phyto, CNH, Crustbuster	Round	1.38	35.0	3.25	82.6	5 Round holes	0.33	8.3
								5 Round holes	0.33	8.3
Round Center hole with 4 oval bolt holes 	89	Argis, CNH	Round	3.97	100.8	5.00	127.0	4 Oval Holes	0.53	13.5
									0.66	16.7
Round Center hole with 2 rings 4&1Rd. bolt holes 	95	CNH, Yetter	Round	1.75	44.5	3.25	82.6	4 Round Holes	0.34	8.7
								1 Round Hole	0.28	7.1
Notched Round Center with 4 round bolt holes 	115	Sustain Ag	Round	2.78	70.5	3.74	95.0	4 Round Holes	0.45	11.5
Round Center hole with 2 rings 6 & 4 blt.holes 	128	Amaco	Round	1.69	42.9	3.13	79.5	6 Round Holes	0.27	6.8
								4 Square Holes	0.34	8.7
Round Center hole with 2 rings 6 & 2 blt.holes 	133	Agco	Round	1.58	40.0	2.75	69.8	6 Round Holes	0.22	5.6
								2 Square Holes	0.34	8.7
No Center hole 4 Round bolt holes 	116	Norwood	None	None	None	3.86	98.0	4 Round Holes	0.52	13.2

Ingersoll Worksheet

Special projects request guide

Special orders are available through your authorized Ingersoll Sales Representative. The worksheets on these pages are provided for your convenience in specifying the products you need.

Full Concavity Discs	Inches	mm
Diameter (D)		
Center Hole Diameter (CHD)		
Thickness (T)		
Number of Notches (NN)		
Concavity (C)		
Concavity Radius (CR)		
Edge Profile		

Marker or Flat Back Disc	Inches	mm
Diameter (D)		
Center Hole Diameter (CHD)		
Thickness (T)		
Number of Notches (NN)		
Concavity (C)		
Concavity Radius (CR)		
Bolt Circle Diameter (BCD)		
Number of Holes (NH)		
Bolt Hole Diameter (BHD)		
Flat Center Diameter (FCD)		
Edge Profile		

Ingersoll Worksheet

Special projects request guide

Special orders are available through your authorized Ingersoll Sales Representative. The worksheets on these pages are provided for your convenience in specifying the products you need.

Opener or Flat Coulter	Inches	mm
Diameter (D)		
Center Hole Diameter (CHD)		
Thickness (T)		
Number of Notches (NN)		
Concavity (C)		
Bolt Circle Diameter (BCD)		
Number of Holes (NH)		
Bolt Hole Diameter (BHD)		
Edge Profile		

Fluted or Rippled Coulter	Inches	mm
Diameter (D)		
Center Hole Diameter (CHD)		
Thickness (T)		
Bolt Circle Diameter (BCD)		
Number of Holes (NH)		
Bolt Hole Diameter (BHD)		
Flute / Wave Height (FH)		
Number of Flutes (NF)		
Edge Profile		



GET THE EDGE
INGERSOLL[®]

**Ideal seedbed preparation.
Your #1 controllable yield factor.**

GET THE EDGE with Ingersoll.

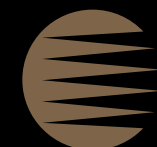

INGERSOLL[®]



www.IngersollTillage.com

(888) 768-1740

sales@IngersollTillage.com

Ingersoll Tillage Group
460 Sherman Ave N
Hamilton, Ontario L8L 8J6, Canada

ISO 9001:2008 Certified

A GROWING BRAND OF  AGRISOLUTIONS